

Calendering Heat Press



Features

- ▶ Cylinder diameter 20 cm /8" heated to oil
- ▶ Production 0,53 mt/min. linear (0,57 yd/min.) respectively of 40 second dwell time
- ▶ System Guide, no. 3 unwinding / nr. 3 reels
- ▶ Electropneumatic control guide felt
- ▶ A proportional working thermostat regulates the temperature with a remarkable energy saving.
- ▶ Auto-off to reach 140°
- ▶ An independent motor for driving the felt and a motor for the three rewinders
- ▶ Pneumatic clutches
- ▶ Requires compressed air

Transmatic 7140 / 7160 SPORTS

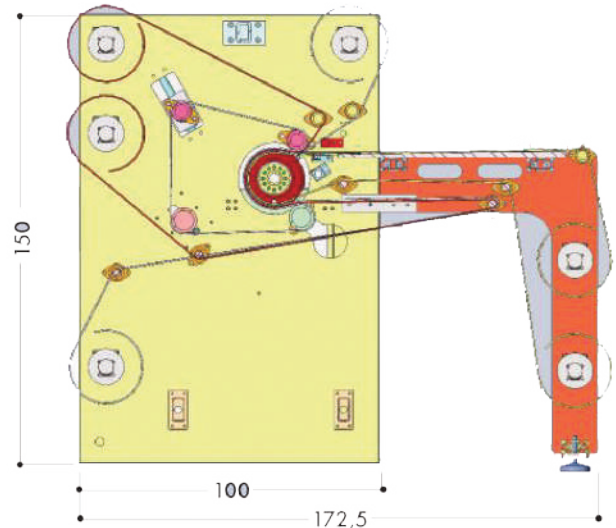
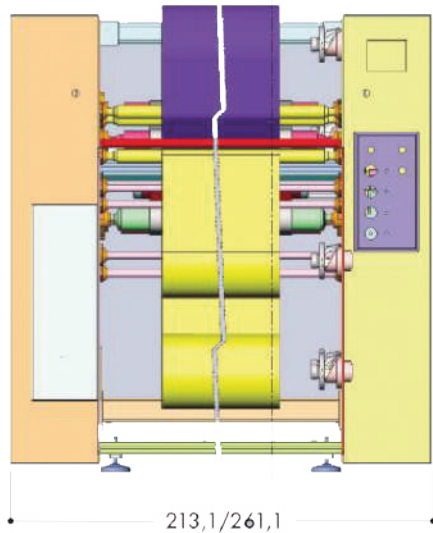

Technical data:

Model	7140 SPORT	7160 SPORT
Power installed	6 kw – 26 a	10.8 kw – 46.9 a
Average consumption	3 kw – 13 a	5 kw – 21.7 a
Belt size	120 cm / 47"	170 cm / 67"
Working width	110 cm / 43"	160 cm / 63"
Net weight	700 kg / 1540 lb.	1000 kg / 2280 lb.
Size	213x173x153 cm / 84x68x60"	263x173x153cm / 103,5x68x60"

The 7140 / 7160 has 3 different modes of operation :

- ▶ Cut fabric pieces lay onto an upwards facing transfer paper
- ▶ Cut fabric pieces and cut transfer pieces (sheet fed)
- ▶ Rolls of transfer paper and fabric (continuous feed)



Fashion



Sports



Interiors



Flags & Banners



Garment Decoration & Textile Printing Solutions

📍 W/H: H2-006
Sharjah Airport International Free Zone
United Arab Emirates

☎ +971 6 557 99 29
✉ Email: multisys@eim.ae
🌐 Web: www.texgraff.com